

megamount 601

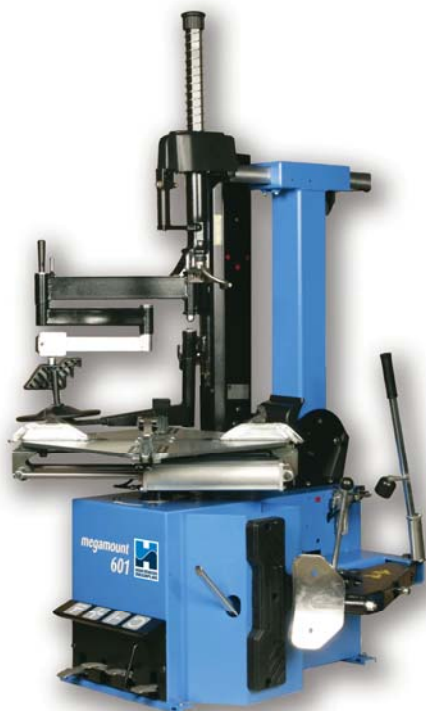

Automatic tyre changer with double speed turntable

That is self-evident for us:

- Pneumatic forward/back swinging mounting arm
- Up and down movement of operating arm by spring
- 2 clamping cylinders
- Clamping adjustable (outside/ inside in inch): 10-20/12-22 or 11-21/13-23 (standard) or 12-22/14-24
- Maximum rim width 15 inches
- Maximum tyre diameter 1000 mm
- Filter with pressure regulator and manometer for 10 bar working pressure
- Inflating pressure limiting device 3,5 bar (CE)

Option Press Arm + megafit

The competition might not have this:

- Bead breaker 2,5 tons also for the stiffest tyres.
- Mounting column with 41mm diameter.
- Double speed turntable bidirectional rotation system, pedal controlled.



For all problems the right solution:



- MOUNTING ARM
Tiltable back and forth pneumatically
- MOUNTING SHAFT
Extreme rigid construction. Manufactured from precision cast-steel. Pneumatic height adjustment
- MOUNTING HEAD
Optimised profile for high efficiency when working with different dimensions of tyres and rims. Automatically keeping distance off the rim when blocked. Adjustable angle for inclination and rotation.



- BEAD BRAKER
Zinc plated high power cylinder 2,5 tons. Special contoured flexible blade for easy, ergonomic working without the risk of damaging tyre or rim.
- CLAMPING SYSTEM
Self-centring four jaw chuck with two rotation speeds (7 und 14 rpm). Markings for the pre-selection of the clamping jaws.

This comes with the machine:

- Lubricator
- Grease holder
- Tyre lever
- 10 bar operating pressure limiting device
- CE 3,5 bar inflating pressure limiting device

Options intelligent and universal

- Filling systems through clamping jaws (Tubeless)
(to be ordered simultaneously with the machine)
- Protecting caps for mounting alloy rims
Allows also tubeless filling of alloy rims
- Bead braking tool **megafit** for extreme low profile tyres
- Pneumatic wheel lift
- Quick locking system for different mounting heads
- Helping arms for the mounting of extreme low profile tyres

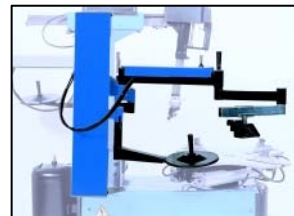

Technical Data	
Compressed air supply	8 to 12 bar
Three-phase motor	230 - 400 V / 50 Hz / 550 W
Motor single phase (Option)	220 V / 50 Hz 750 W
Self-centring lock external adjustable	10 - 22 inches
Self-centring lock internal adjustable	12 - 24 inches
Max wheel diameter	1000 mm
Max rim width	15 inches
Bead braker pressure	3200 kg
Dimensions, packed (WxDxH)	1080x920x1070 mm
Gross weight, packed	290 kg

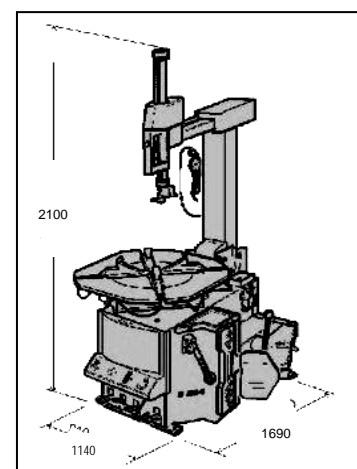

HOFMANN MEGAPLAN GMBH
Hauptstraße 59
A-5302 Henndorf · Austria
Tel: +43-6214-646612 Fax - 646622
company@hofmann-megaplan.com
www.hofmann-megaplan.com