

megamount 701



Option help arms

Automatic tyre changer with Quadraclamp 4- clamping cylinders.

That is self-evident for us:

- Pneumatic forward/back swinging mounting arm
- Up and down movement of operating arm by spring
- Rim clamping inside 12-26 inches, outside 10-24 inches
- Maximum rim width 15 inches
- Maximum tyre diameter 1000 mm
- 10 bar operating pressure regulator with manometer and water separator
- Inflating pressure limiting device 3,5 bar (CE)

The competition might not have this:

- Bead breaker 3,2 tons also for the stiffest tyres.
- Mounting column with 41mm diameter.
- Double speed turntable bidirectional rotation system with hand switch.
- Hand lock to additionally fix the horizontal part of the mounting arm



For all problems the right solution:



- MOUNTING ARM
- MOUNTING SHAFT
- MOUNTING HEAD

Tiltable back and forth pneumatically

Extreme rigid construction. Manufactured from precision cast-steel. Pneumatic height adjustment

Optimised profile for high efficiency when working with different dimensions of tyres and rims. AUTOMATIC ANGLE MECHANISM for correct setting in vertical, horizontal and diagonal position.



- BEAD BRAKER
- CLAMPING SYSTEM

Zinc plated high power cylinder 3,2 tons. Special contoured flexible blade

Self-centring four jaw chuck with two rotation speeds (7 und 14 rpm). Markings for the pre-selection of the clamping jaws.

This comes with the machine:

- Lubricator
- Grease holder
- Tyre lever
- 10 bar operating pressure regulator with manometer and water separator
- CE 3,5 bar inflating pressure limiting device

Options intelligent and universal

- Filling systems through clamping jaws (Tubeless) (to be ordered simultaneously with the machine)
- Protecting caps for mounting alloy rims
Allows also tubeless filling of alloy rims
- Bead braking tool **megafit** for extreme low profile tyres
- Pneumatic wheel lift
- Quick locking system for different mounting heads
- Helping arms for the mounting of extreme low profile tyres

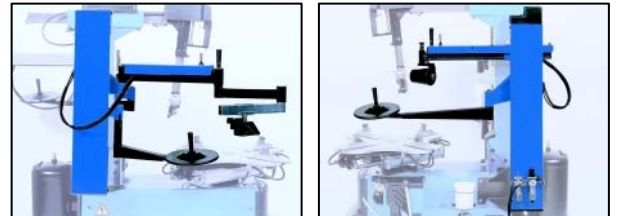
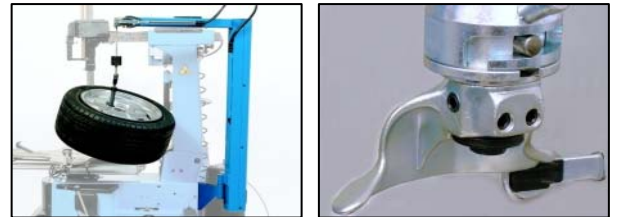
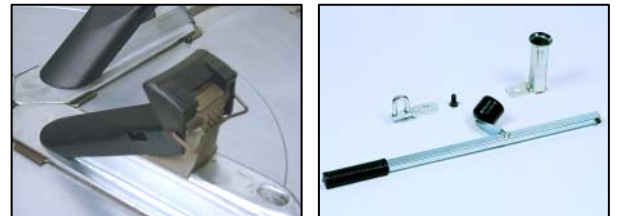
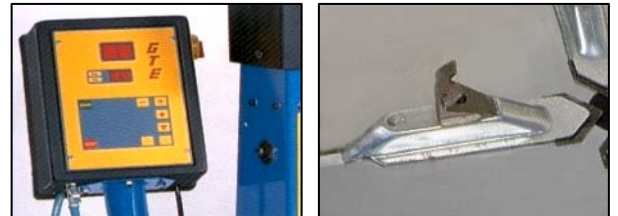

| Technical Data | |
|-----------------------------|-----------------------------|
| Compressed air supply | 8 to 12 bar |
| Three-phase motor | 230 - 400 V / 50 Hz / 550 W |
| Motor single phase (Option) | 220 V / 50 Hz 750 W |
| Self-centring lock external | 10 - 24 inches |
| Self-centring lock internal | 12 - 26 inches |
| Max wheel diameter | 1000 mm |
| Max rim width | 15 inches |
| Bead braker pressure | 3200 kg |
| Dimensions, packed (WxDxH) | 1080x920x1070 mm |
| Gross weight, packed | 290 kg |

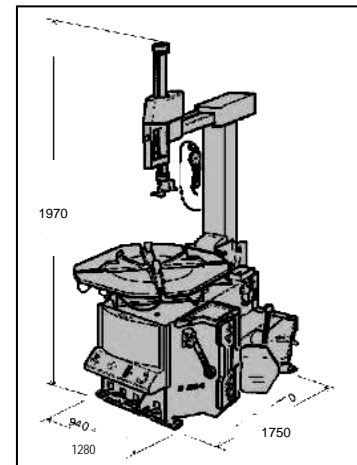

HOFMANN MEGAPLAN GMBH
 Hauptstraße 59
 A-5302 Henndorf · Austria
 Tel: +43-6214-646612 Fax - 646622
company@hofmann-megaplan.com
www.hofmann-megaplan.com